

# User Manual



## **P7240** **4 GHz 5X Active Probe** **071-0759-02**

### **Warning**

The servicing instructions are for use by qualified personnel only. To avoid personal injury, do not perform any servicing unless you are qualified to do so. Refer to all safety summaries prior to performing service.

**[www.tektronix.com](http://www.tektronix.com)**

Copyright© Tektronix, Inc. All rights reserved.

Tektronix products are covered by U.S. and foreign patents, issued and pending. Information in this publication supercedes that in all previously published material. Specifications and price change priviledges reserved.

Tektronix, Inc., P.O. Box 500, Beaverton, OR 97077

TEKTRONIX, TEK, and SureFoot are registered trademarks, and TekConnect, SureToe, and KlipChip are trademarks of Tektronix, Inc.

## WARRANTY

Tektronix warrants that this product will be free from defects in materials and workmanship for a period of one (1) year from the date of shipment. If any such product proves defective during this warranty period, Tektronix, at its option, either will repair the defective product without charge for parts and labor, or will provide a replacement in exchange for the defective product.

In order to obtain service under this warranty, Customer must notify Tektronix of the defect before the expiration of the warranty period and make suitable arrangements for the performance of service. Customer shall be responsible for packaging and shipping the defective product to the service center designated by Tektronix, with shipping charges prepaid. Tektronix shall pay for the return of the product to Customer if the shipment is to a location within the country in which the Tektronix service center is located. Customer shall be responsible for paying all shipping charges, duties, taxes, and any other charges for products returned to any other locations.

This warranty shall not apply to any defect, failure or damage caused by improper use or improper or inadequate maintenance and care. Tektronix shall not be obligated to furnish service under this warranty a) to repair damage resulting from attempts by personnel other than Tektronix representatives to install, repair or service the product; b) to repair damage resulting from improper use or connection to incompatible equipment; or c) to service a product that has been modified or integrated with other products when the effect of such modification or integration increases the time or difficulty of servicing the product.

**THIS WARRANTY IS GIVEN BY TEKTRONIX WITH RESPECT TO THIS PRODUCT IN LIEU OF ANY OTHER WARRANTIES, EXPRESSED OR IMPLIED. TEKTRONIX AND ITS VENDORS DISCLAIM ANY IMPLIED WARRANTIES OF MERCHANTABILITY OR FITNESS FOR A PARTICULAR PURPOSE. TEKTRONIX' RESPONSIBILITY TO REPAIR OR REPLACE DEFECTIVE PRODUCTS IS THE SOLE AND EXCLUSIVE REMEDY PROVIDED TO THE CUSTOMER FOR BREACH OF THIS WARRANTY. TEKTRONIX AND ITS VENDORS WILL NOT BE LIABLE FOR ANY INDIRECT, SPECIAL, INCIDENTAL, OR CONSEQUENTIAL DAMAGES IRRESPECTIVE OF WHETHER TEKTRONIX OR THE VENDOR HAS ADVANCE NOTICE OF THE POSSIBILITY OF SUCH DAMAGES.**

# Table of Contents

<b>General Safety Summary</b> .....	<b>iii</b>
<b>Preface</b> .....	<b>v</b>
Related Manuals .....	v
Contacting Tektronix .....	vi
<b>Product Description</b> .....	<b>1</b>
TekConnect Interface .....	1
Installation .....	2
Options .....	3
<b>Features and Accessories</b> .....	<b>5</b>
<b>Functional Check</b> .....	<b>13</b>
<b>Configuration</b> .....	<b>15</b>
Probe Offset .....	15
<b>Operating Basics</b> .....	<b>17</b>
Handling the Probe .....	17
Maximum Nondestructive Input Voltage .....	17
Input Linear Dynamic Range .....	17
Ground Lead Length .....	18
Ground Lead Inductance .....	18
<b>Helpful Hints</b> .....	<b>21</b>
Low-inductance Grounding .....	21
SureFoot Grounding .....	22
<b>Appendix A: Specifications</b> .....	<b>23</b>
Specifications .....	23
<b>Appendix B: User Service</b> .....	<b>27</b>
Inspection and Cleaning .....	27
Calibration .....	27
Replacement Parts .....	27
Preparation for Shipment .....	28
<b>Appendix C: Replaceable Parts</b> .....	<b>29</b>
Parts Ordering Information .....	29
Using the Replaceable Parts List .....	30

## List of Figures

<b>Figure 1: P7240 Probe featuring the TekConnect interface</b>	<b>1</b>
<b>Figure 2: Connecting and disconnecting the probe</b> .....	<b>2</b>
<b>Figure 3: Probe functional check connections</b> .....	<b>13</b>
<b>Figure 4: Dynamic and offset limitations</b> .....	<b>16</b>
<b>Figure 5: Waveform distortion from ground lead length</b> ..	<b>18</b>
<b>Figure 6: Ground Lead Equivalent Circuit</b> .....	<b>19</b>
<b>Figure 7: Low-inductance grounding</b> .....	<b>21</b>
<b>Figure 8: Using a SureFoot adapter for grounding</b> .....	<b>22</b>
<b>Figure 9: Typical input impedance and phase versus frequency</b> .....	<b>24</b>
<b>Figure 10: Typical bandwidth</b> .....	<b>25</b>
<b>Figure 11: Probe head and compensation box dimensions</b> .	<b>25</b>
<b>Figure 12: P7240 replaceable parts</b> .....	<b>31</b>
<b>Figure 13: P7240 standard accessories</b> .....	<b>32</b>
<b>Figure 14: P7240 optional accessories</b> .....	<b>34</b>

# General Safety Summary

Review the following safety precautions to avoid injury and prevent damage to this product or any products connected to it. To avoid potential hazards, use this product only as specified.

*Only qualified personnel should perform service procedures.*

## To Avoid Fire or Personal Injury

**Connect and Disconnect Properly.** Connect the probe output to the measurement instrument before connecting the probe to the circuit under test. Disconnect the probe input and the probe ground from the circuit under test before disconnecting the probe from the measurement instrument.

**Observe All Terminal Ratings.** To avoid fire or shock hazard, observe all ratings and markings on the product. Consult the product manual for further ratings information before making connections to the product.

Connect the ground lead of the probe to earth ground only.

**Do Not Operate Without Covers.** Do not operate this product with covers or panels removed.

**Do Not Operate With Suspected Failures.** If you suspect there is damage to this product, have it inspected by qualified service personnel.

**Do Not Operate in Wet/Damp Conditions.**

**Do Not Operate in an Explosive Atmosphere.**

**Keep Product Surfaces Clean and Dry.**

## Safety Terms and Symbols

**Terms in This Manual.** These terms may appear in this manual:



---

**WARNING.** *Warning statements identify conditions or practices that could result in injury or loss of life.*

---



---

**CAUTION.** *Caution statements identify conditions or practices that could result in damage to this product or other property.*

---

**Terms on the Product.** These terms may appear on the product:

DANGER indicates an injury hazard immediately accessible as you read the marking.

WARNING indicates an injury hazard not immediately accessible as you read the marking.

CAUTION indicates a hazard to property including the product.

**Symbols on the Product.** These symbols may appear on the product:



CAUTION  
Refer to Manual



# Preface

This is the User Manual for the P7240 probe. This manual provides operating information, specifications, and a replaceable parts list.

## Related Manuals

If you need to do a performance verification or make internal adjustments to your probe, refer to the *P7240 4 GHz Active Probe Service Manual*, Tektronix part number 071-1056-XX. The manual is a printable pdf file, and is available on both the Tektronix website and the Optional Applications CD, Tektronix part number 063-3376-XX. The Optional Applications CD is included with Tektronix oscilloscopes featuring the TekConnect interface.



## Contacting Tektronix

<b>Phone</b>	1-800-833-9200*
<b>Address</b>	Tektronix, Inc. Department or name (if known) 14200 SW Karl Braun Drive P.O. Box 500 Beaverton, OR 97077 USA
<b>Web site</b>	<a href="http://www.tektronix.com">www.tektronix.com</a>
<b>Sales support</b>	1-800-833-9200, select option 1*
<b>Service support</b>	1-800-833-9200, select option 2*
<b>Technical support</b>	Email: <a href="mailto:techsupport@tektronix.com">techsupport@tektronix.com</a> 1-800-833-9200, select option 3* 1-503-627-2400 6:00 a.m. - 5:00 p.m. Pacific time

---

\* **This phone number is toll free in North America. After office hours, please leave a voice mail message. Outside North America, contact a Tektronix sales office or distributor; see the Tektronix web site for a list of offices.**

## Product Description

The Tektronix P7240 is a 4 GHz (probe only), 5X active FET probe. The P7240 has a low input capacitance (1 pF) and high input resistance (20 k $\Omega$ ), which minimize circuit loading over a wide bandwidth range. The small profile and low-mass head of the P7240 make probing dense circuitry by hand fast and easy. The accessory tips and adapters included enable the P7240 to be used on a wide variety of circuit architectures.

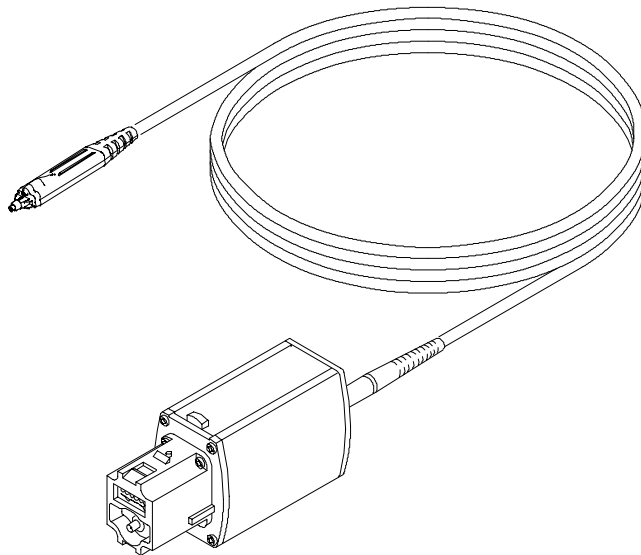

**Figure 1: P7240 Probe featuring the TekConnect interface**

### TekConnect Interface

The P7240 is powered through a TekConnect interface between the probe compensation box and the oscilloscope. The TekConnect interface provides a communication path through contact pins on the host instrument. Power, signal, offset, and probe characteristic data transfer through the interface.

When the probe is connected, the oscilloscope reads EEPROM information from the probe, identifying the device and allowing the appropriate power supplies to be powered on. The preamp inputs on the oscilloscope are electrostatic discharge protected by remaining grounded until a valid TekConnect device is detected.

## Installation

The TekConnect interface features a spring-loaded latch that provides audible and tactile confirmation that a reliable connection has been made to the oscilloscope. Slide the probe into the TekConnect receptacle on the oscilloscope. The probe snaps into the oscilloscope when fully engaged. See Figure 2.

To release the probe from the oscilloscope, grasp the compensation box, depress the latch button, and pull out the probe.

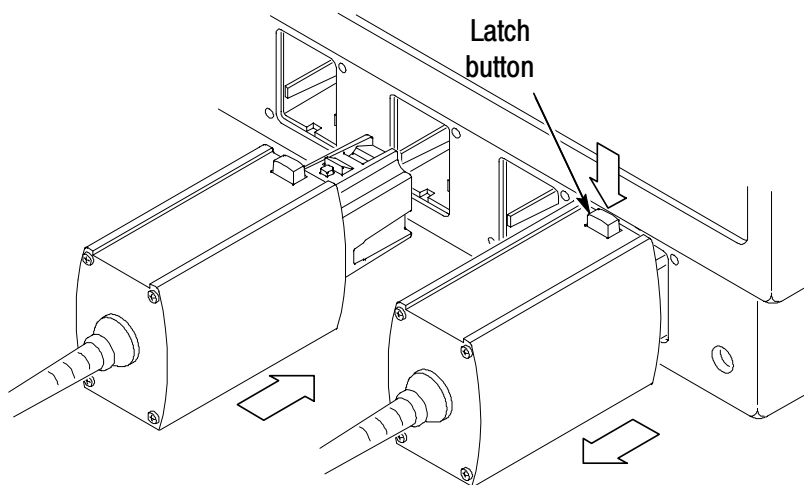

**Figure 2: Connecting and disconnecting the probe**

## Options

The following options are available when ordering the P7240 probe:

- Option D1 - Calibration Data
- Option C3 - 3 years Calibration Service
- Option D3 - 3 years Calibration Data (requires Option C3)
- Option R3 - 3 years Extended Warranty



# Features and Accessories

The P7240 is provided with several features and accessories designed to make probing and measurement a simpler task. To familiarize yourself with these items and their uses, refer to Table 1.

**Table 1: P7240 features and standard accessories**

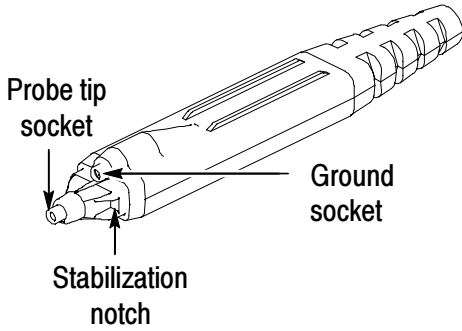
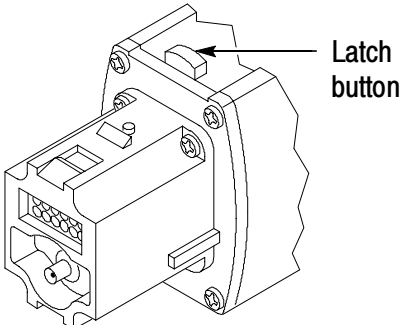
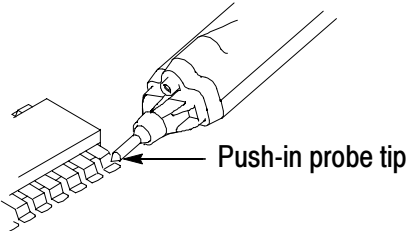
Feature/Accessory	Description
 <p>Probe tip socket</p> <p>Ground socket</p> <p>Stabilization notch</p>	<p><b>Probe head assembly.</b> The probe head is designed for ease of use and high performance. Its small size makes it easy to handle in tight areas.</p> <p>The probe tip socket is sized to easily press onto 0.025 inch square pins for direct access. The ground socket provides a short ground path for high fidelity ground connections.</p> <p>The stabilization notch permits you to use adjacent pins to reduce stresses on the probe and pins.</p>
 <p>Latch button</p>	<p><b>TekConnect interface.</b> The TekConnect interface provides a communication path between the probe and the oscilloscope. Contact pins provide power, signal, offset, and probe characteristic data transfer.</p> <p>The probe snaps into the oscilloscope when fully engaged. To remove, grasp the compensation box, depress the latch button, and pull the probe out.</p>
 <p>Push-in probe tip</p>	<p><b>Push-in probe tip (10 ea).</b> Use the push-in probe tip for general purpose probing by hand.</p> <p>The push-in probe tip may also be used with the other socketed leads and adapters.</p> <p>Tektronix part number: 131-5638-11 (package of 10)</p>

**Table 1: P7240 features and standard accessories (Cont.)**

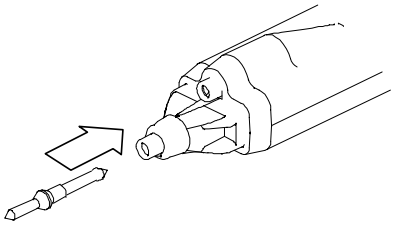
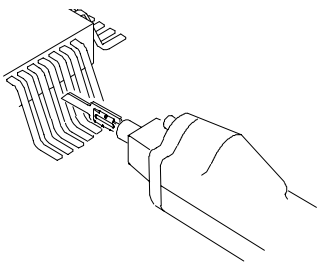
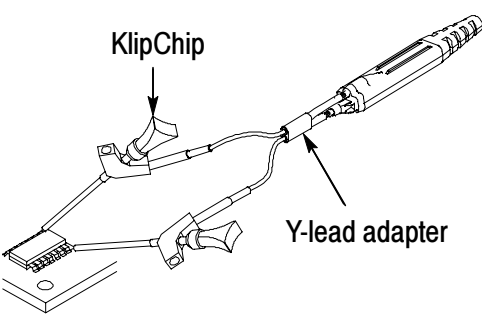
Feature/Accessory	Description
	<p><b>Installing the push-in probe tip.</b> Attach the push-in probe tip by aligning the tip into the probe tip socket and pushing the tip in until it is seated. Either end of the tip may be used.</p> <p>Do not force the tip. Also, be careful not to poke yourself with the sharp probe tip. To remove the tip, gently grab the tip with small pliers, and pull the tip out.</p>
	<p><b>SureToe probe tip (4 ea).</b> The SureToe tip is a pointed probe tip useful for probing in dense circuitry. Attach the SureToe adapters the same way as the push-in probe tips.</p> <p>Do not force the tip. Also, be careful not to poke yourself with the sharp probe tip. They can be used with any of the socketed accessory leads.</p> <p>Tektronix part number: ST501 (package of 12)</p>
	<p><b>SMT KlipChip (2 ea).</b> Use the SMT KlipChip test clips to access fragile, dense circuitry.</p> <p>KlipChip test clips can be connected to the Y-lead or three-inch ground leads. Simply press the lead socket into the KlipChip handle.</p> <p>The KlipChip body freely turns, allowing better probe orientation. To reduce stress and provide a lower profile on components being tested, the flexible sleeve of the KlipChip bends up to a 35 degree angle.</p> <p>Tektronix part number: 206-0364-XX</p>

**Table 1: P7240 features and standard accessories (Cont.)**

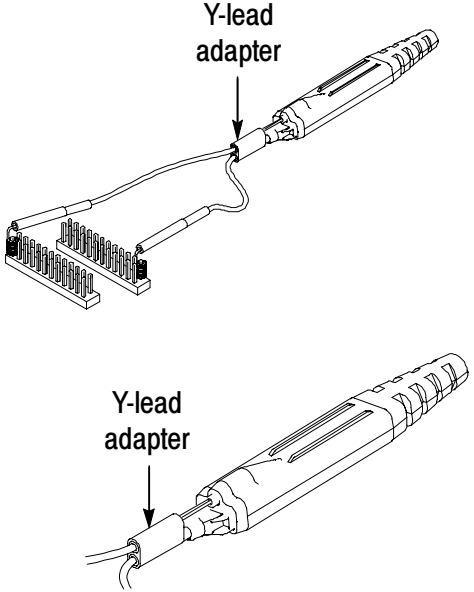
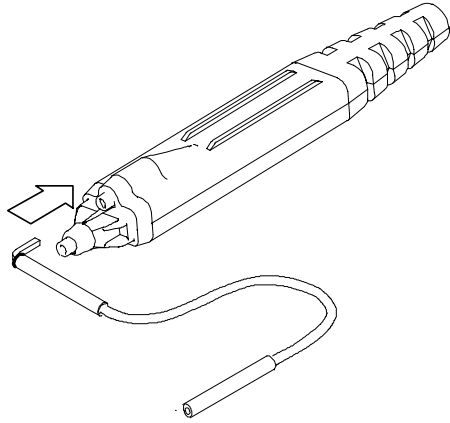
Feature/Accessory	Description
 <p>The top diagram shows a Y-lead adapter being pushed onto a probe tip. The bottom diagram shows the Y-lead adapter being inserted into the ground socket on the probe head.</p>	<p><b>Y-lead adapter (2 ea).</b> Use the Y-lead adapter to extend the physical reach of the probe and ground when necessary. The Y-lead adapter accepts any of the probe tips or adapters, and can be pushed directly onto 0.025 inch square-pins.</p> <p>When selecting the grounding connection, maintain as short a ground path as possible. Refer to page 18 for more information.</p> <p>To attach the Y-lead adapter, gently press the lead pins into the probe head tip and ground receptacles. Using the black lead for ground is recommended.</p>
 <p>The diagram shows a three-inch ground lead being inserted into the ground socket on the probe head.</p>	<p><b>Three-inch ground lead (3 ea).</b> Use the three-inch ground lead for general probing. The socketed end of the lead may be connected to any of the probe tips and adapters or fitted onto 0.025 inch square pins.</p> <p>To attach the ground lead, press and rotate the lead pin connector into the ground socket on the probe head. The lead may be removed by simply pulling the pin out by hand.</p> <p>When selecting the grounding connection, maintain as short a ground path as possible. Refer to page 18 for more information.</p> <p>Tektronix part number: 196-3456-00 (package of three ground leads and two Y-lead adapters)</p>

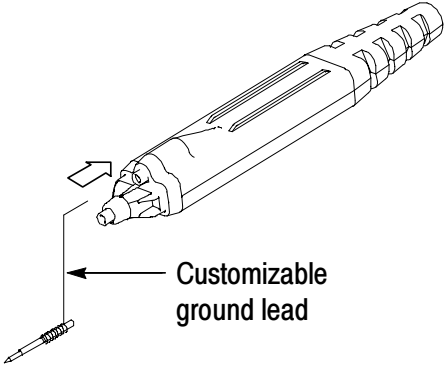
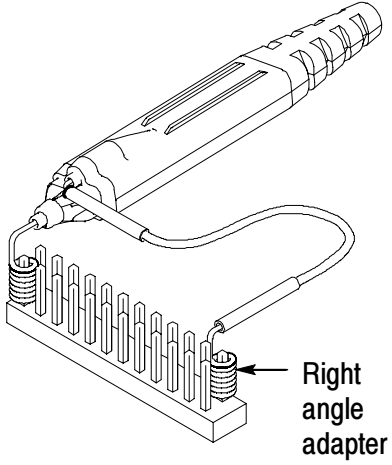

**Table 1: P7240 features and standard accessories (Cont.)**

Feature/Accessory	Description
	<p><b>Customizable ground lead (5 ea).</b> This ground lead wire can be bent or cut shorter.</p> <p><b>NOTE:</b> To ease insertion into the ground socket of the probe, cut the tip of this ground lead wire at a 30 to 60 degree angle.</p> <p>To maintain signal fidelity while probing, use as short a ground path as possible. Refer to page 18 for more grounding information.</p> <p>Tektronix part number: 196-3482-00 (package of 5)</p>
	<p><b>Adapter spring (10 ea).</b> Use the adapter spring for low-profile probing of 0.025 inch square pins.</p> <p>The adapter spring allows the probe to lie at a right-angle (flat against a circuit board). This enables probing in vertical circuits, such as computer or communications backplanes, or in tight areas, such as between circuit cards.</p> <p>The adapter can be used directly with the probe head or attached to the Y-lead adapter or ground leads.</p> <p>The adapter is attached by pushing the tip into the probe tip socket until it is seated. The adapter spring can be easily removed by hand.</p> <p>Tektronix part number: 016-1774-00 (package of 10)</p>

**Table 1: P7240 features and standard accessories (Cont.)**

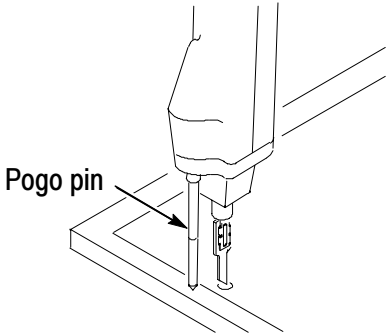
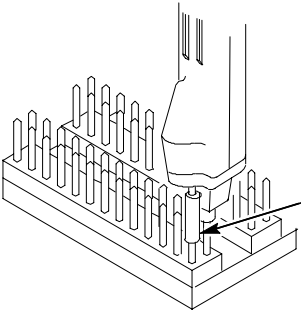
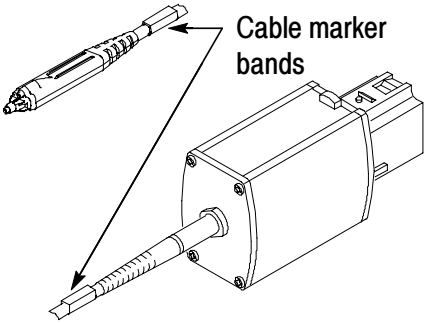
Feature/Accessory	Description
 <p>Pogo pin</p>	<p><b>Low-inductance ground pogo pin (10 ea).</b> Use the low-inductance ground pogo pin to substantially reduce ground lead inductance. Because the pogo pin simply touches the ground reference, you can easily move the probe to different points on the circuit under test.</p> <p>To attach, press the pogo pin into the probe head ground socket.</p> <p>When selecting the grounding connection, maintain as short a ground path as possible. Refer to page 18 for more information.</p> <p>Tektronix part number: 016-1772-10 (package of 10)</p>
 <p>Ground pin length adapter</p>	<p><b>Ground pin length adapter (10 ea).</b> The ground pin length adapter is ideal for use with signal/ground pairs on 0.100 inch square-header pins.</p> <p>Attach the adapter by gently pressing it into the ground socket on the probe head.</p> <p>Be sure to use the stabilization notch whenever possible to avoid slipping and damaging the probe or circuitry under test.</p> <p>Tektronix part number: 016-1773-10 (package of 10)</p>
 <p>Cable marker bands</p>	<p><b>Cable marker bands (10 ea).</b> Attach matching pairs of the marker bands onto the cable at the head and compensation box of each probe. The marker bands enable quick verification of which probe is connected to which instrument channel.</p> <p>Tektronix part number: 016-1315-00 (package of 10)</p>

**Table 1: P7240 features and standard accessories (Cont.)**



Feature/Accessory	Description
	<p><b>Antistatic wrist strap.</b> When using the probe, always work at an antistatic work station and wear the antistatic wrist strap.</p> <p>Tektronix part number: 006-3415-04</p>
	<p><b>Plastic accessory box.</b> Use the plastic box to store the probe accessories when not in use.</p> <p>Tektronix part number: 006-7164-00</p>
	<p><b>Instrument case.</b> The instrument case protects the probe from harsh environments and provides room for storing optional accessories.</p> <p>Tektronix part number: 016-1879-01</p>
	<p><b>Instruction Manual.</b> Provides specifications and instructions for operating the probe, and a list of accessories and adapters.</p> <p>Tektronix part number: 071-0759-XX</p>
	<p><b>Calibration certificate.</b> A certificate of traceable calibration is provided with every instrument shipped.</p>

Table 2 lists the optional accessories you can order for your P7240 probe.

**Table 2: P7240 optional accessories**

Accessory	Description
	<p><b>SureFoot probe tip.</b> The SureFoot tip is an integral probe tip and miniature guide that enables fault-free probing of fine-pitch SMD packages.</p> <p>Attach SureFoot tips the same way as the push-in probe tips. Three models of SureFoot tips are included with the probe and can be used with any of the socketed accessory leads.</p>
	<p><b>SF501.</b> The orange SureFoot tip is compatible with 50 mil JEDEC packages such as SOIC, PLCC, CLCC, and so on.</p> <p>Tektronix part number: SF501 (package of 12)</p>
	<p><b>SF502.</b> The blue SureFoot tip is compatible with 0.65 mm JEDEC and EIAJ packages.</p> <p>Tektronix part number: SF502 (package of 12)</p>
	<p><b>SF503.</b> The red SureFoot tip is compatible with EIAJ packages.</p> <p>Tektronix part number: SF503 (package of 12)</p>
	<p><b>Micro KlipChip adapters (4 ea).</b> Use the adapters to probe the leads on integrated circuits that are surface-mounted.</p> <p>Tektronix part number: SMK4 (package of 4)</p>

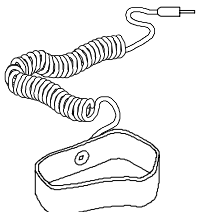
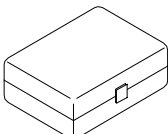
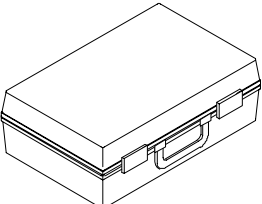
**Table 2: P7240 optional accessories (Cont.)**

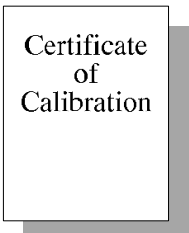
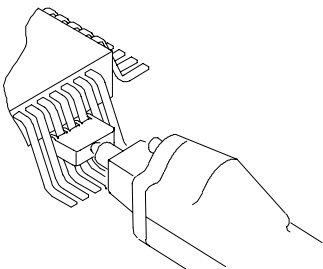
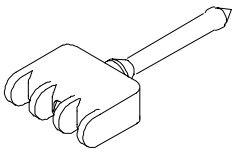
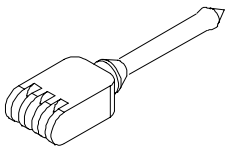
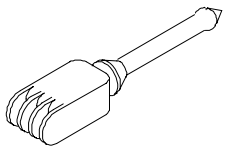
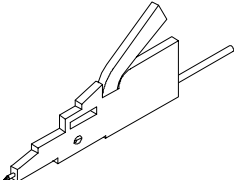
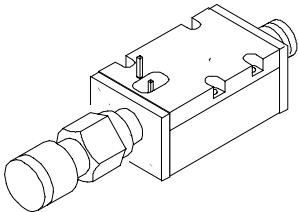
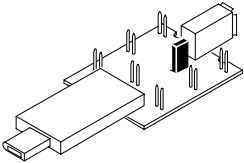
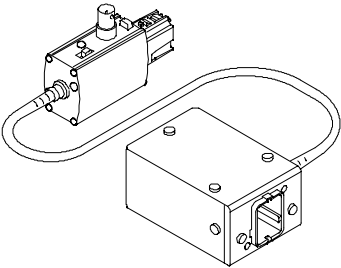
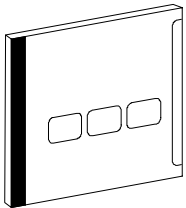
Accessory	Description
	<p><b>SMA-to-probe tip adapter.</b> Use the adapter to connect the probe to SMA cables. The adapter includes a 50-ohm SMA terminator.</p> <p>Tektronix part number: 015-0678-00</p>
	<p><b>IEEE1394 Adapter.</b> The IEEE1394 Adapter allows you to probe signals on the bus, external to system enclosures, without disturbing system operation. The adapter maintains a balanced 55-ohm signal path and can be used in both single-ended and differential modes.</p> <p>Tektronix part number: 679-5027-00</p>
	<p><b>TekConnect interface calibration fixture.</b> The calibration fixture is required when a performance verification or adjustment is done on the probe. It provides connectors and test points for internal probe measurements.</p> <p>Tektronix part number: 067-0422-00</p>
	<p><b>Calibration software and instructions.</b></p> <p>Use the Optional Applications Software CD that is shipped with oscilloscopes featuring the TekConnect interface. Alternatively, you can download the software from the Tektronix website, or order the CD using the part number below.</p> <p>Tektronix part number: 063-3376-XX</p>

# Functional Check

A functional check may be performed using the PROBE COMPENSATION connections on the front panel of the oscilloscope. See Figure 3.

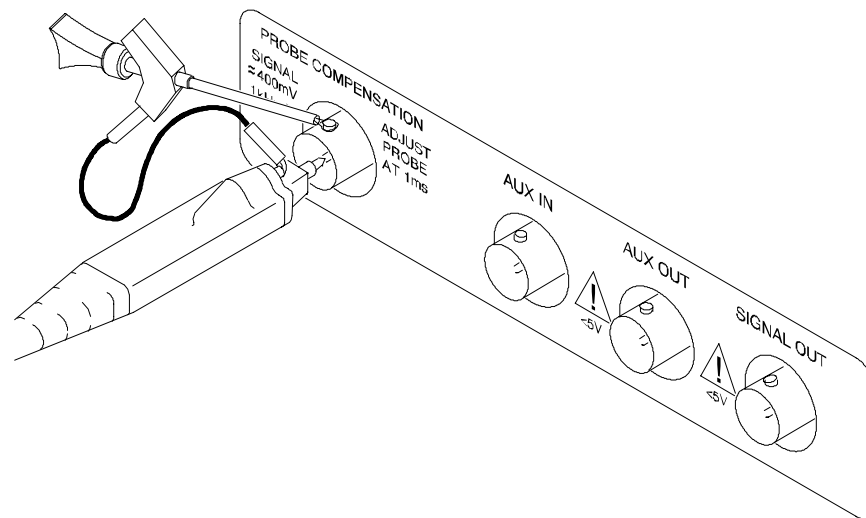

**Figure 3: Probe functional check connections**

1. Connect the probe to a TekConnect receptacle on the oscilloscope.
2. Set the oscilloscope to display the appropriate probe channel.
3. Using a ground lead and SMT KlipChip, connect the probe ground to the outer ring of the PROBE COMPENSATION connector on the oscilloscope.
4. Using a standard tip, hold the probe to the center conductor of the PROBE COMPENSATION BNC connector on the oscilloscope.
5. Press **AUTOSET**, or adjust the oscilloscope to display a stable calibration waveform. (You may need to adjust the probe offset to display the waveform.)

---

**NOTE.** *Now is a good time to perform a probe calibration routine from your instrument.*

---

6. Disconnect the probe tip from the oscilloscope, and ground the probe tip. (Connect the KlipChip to the probe tip.)
7. With the probe offset set to 0.0 V, the oscilloscope display should be at the ground reference.
8. Set the oscilloscope volts/division to 500 mV.
9. Adjust the probe offset. The displayed waveform should vary between approximately +1.0 V and -1.0 V.

# Configuration

The P7240 provides the oscilloscope with the probe model number, serial number, and attenuation factor. When connected to an oscilloscope with a TekConnect interface, display readouts are corrected for the probe attenuation factor, the instrument input is set to 50  $\Omega$ , and the coupling is set to DC. The probe offset control is controlled by the oscilloscope.

## Probe Offset

The probe offset is adjustable to permit operation within the linear range of the probe. Using the offset to cancel DC signal components enables optimal probe performance. See Figure 4 on page 16 for more information.

---

**NOTE.** See your oscilloscope manual for specific instructions on its operation and offset control.

---

To set the probe offset, follow these steps:

1. Ground the input of the probe.
2. Use the vertical position control to set a zero reference level on the oscilloscope display.
3. Set the oscilloscope to 1 V/div.
4. Attach the probe to the circuit.
5. Adjust the probe offset to bring the trace to the oscilloscope zero reference.
6. Change the volts/division setting to the desired range, adjusting the offset to keep the trace on the zero reference level.



**NOTE.** The P7240 has a  $\pm 5.0$  V offset range. The linear operating range is  $\pm 2.0$  V. See Figure 4.

If cursors are used on a TekConnect interface oscilloscope, the zero reference will be at the probe offset voltage.

---

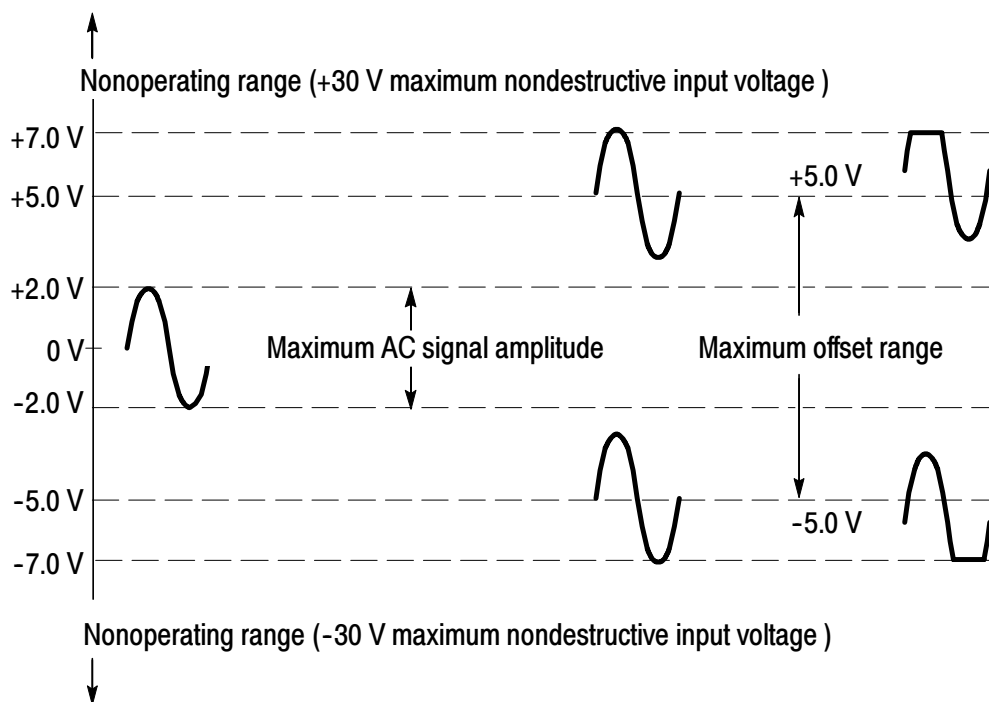

**Figure 4: Dynamic and offset limitations**

# Operating Basics

Please follow these operating guidelines to get optimum performance from your P7240 probe.

## Handling the Probe

Exercise care when using and storing the P7240. The probe and cable are susceptible to damage caused by careless use. Always handle the probe using the compensation box and probe head, avoiding undue physical strain to the probe cable, such as kinking, excessive bending, or pulling. Visible dents in the cable will increase signal aberrations. Do not drop the probe or subject it to physical shock. Damage to the probe may result.

## Maximum Nondestructive Input Voltage

The P7240 is electrically protected against static voltage; however, applying voltages above its design limits may damage the probe tip amplifier. Refer to *Specifications* on page 23 for the maximum operating voltage and frequency derating information.

## Input Linear Dynamic Range

The probe head amplifier used by the P7240 has a limited linear operating range. To keep the input linearity error less than 1.0%, you must limit the apparent signal input voltage to  $\pm 2.0$  V.

Use the DC offset adjustment to maintain the probe within its dynamic range. The nominal offset adjustment range of the P7240 is  $\pm 5.0$  VDC.

---

**NOTE.** *The probe can tolerate input voltages of  $\pm 30$  V without damage; however, the linearity error specification does not apply to input voltages exceeding  $\pm 7.0$  V (including any DC offset). See Figure 4 on page 16.*

---

## Ground Lead Length

When you are probing a circuit, you should always use as short a ground lead as possible between the probe head and circuit ground.

The series inductance added by the probe tip and ground lead can result in a resonant circuit; this circuit may cause parasitic ringing within the bandwidth of your oscilloscope. Refer to Figure 5.

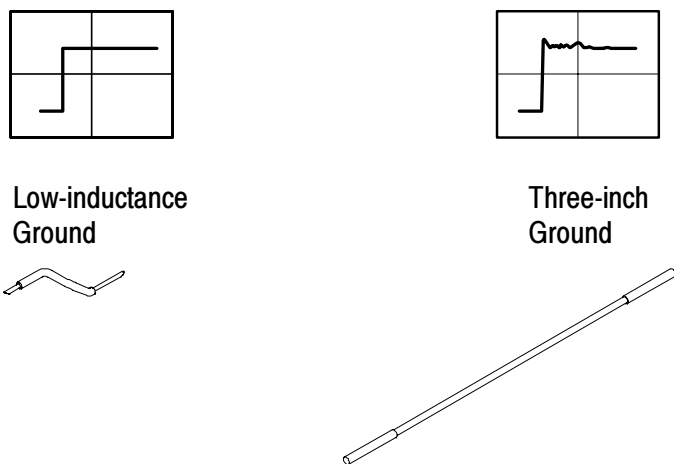

**Figure 5: Waveform distortion from ground lead length**

### Ground Lead Inductance

When you touch your probe tip to a circuit element, you are introducing a new resistance, capacitance, and inductance into the circuit. Refer to Figure 6 on page 19.

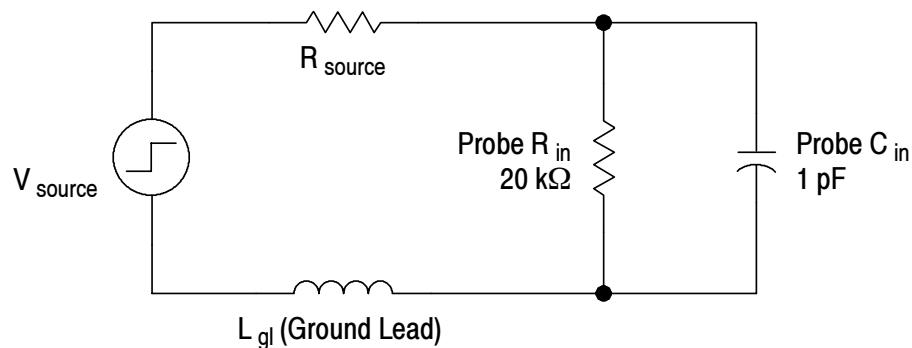

**Figure 6: Ground Lead Equivalent Circuit**

Ringings and rise time degradation can be masked if the frequency content of the signal degradation is beyond the bandwidth of the oscilloscope.

You can determine if ground lead effects may be a problem in your application if you know the self-inductance ( $L$ ) and capacitance ( $C$ ) of your probe and ground lead. Calculate the approximate resonant frequency ( $f_0$ ) at which this parasitic circuit will resonate with the following formula:

$$f_0 = \frac{1}{2\pi\sqrt{LC}}$$

The preceding equation shows that reducing the ground lead inductance will raise the resonant frequency. If your measurements are affected by ringing, your goal is to lower the inductance of your ground path until the resulting resonant frequency is well above the frequency of your measurements.

The low-inductance ground contacts described in *Features and Accessories* starting on page 5 can help you reduce the effects of ground lead inductance on your measurements.



# Helpful Hints

Follow these helpful hints to make probing easier and noise free.

## Low-inductance Grounding

Placing a ground plane on top of a package being probed can minimize ground lead length and inductance. See Figure 7.

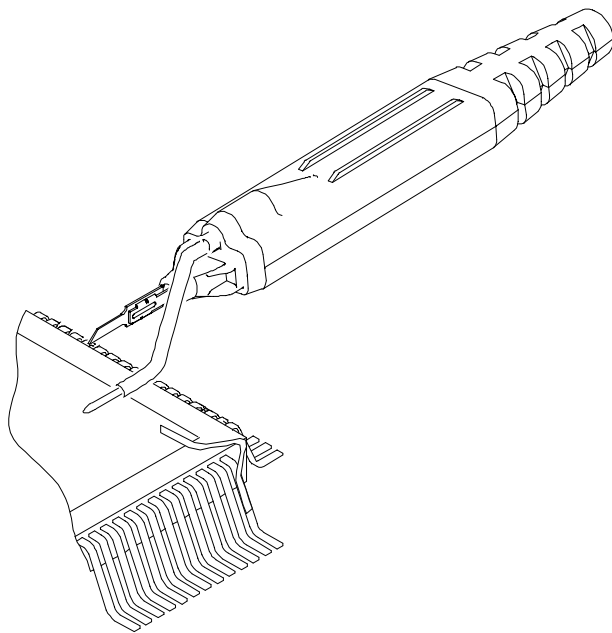

**Figure 7: Low-inductance grounding**

Attach a small piece of copper clad on top of the package and connect it to the package ground connection. Use the low-inductance ground lead provided with the P7240 to keep the ground lead length as short as possible.

This method is very useful when making many measurements on the same package. Using a ground plane on the package makes probing the package easier and avoids adding unnecessary ground lead length and distortion.

### **SureFoot Grounding**

If you cannot use the recommended low-inductance grounding method, you may ground the probe to the package under test using a SureFoot adapter. Refer to Figure 8.

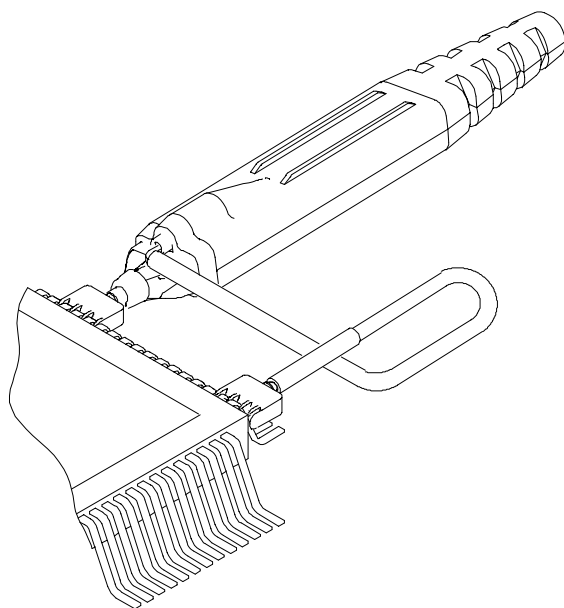

**Figure 8: Using a SureFoot adapter for grounding**

Use a SureFoot adapter at the end of a short ground lead to connect directly to the package ground. This method is preferred over using an adjacent circuit ground because it is the shortest ground path possible.

# Appendix A: Specifications

These specifications apply to a P7240 probe when used with a TDS7404 oscilloscope.

The probe and oscilloscope must first be allowed to warm up for 20 minutes before measurements are taken.

## Specifications



**CAUTION.** To prevent damage to the probe or circuit under test, do not apply voltages beyond the nondestructive input voltage range to the probe.

**Table 3: Warranted electrical specifications**

DC Attenuation Accuracy (probe only)	0.2 $\pm$ 2% (excludes offset error)
Output Zero	$\pm$ 10 mV or less at output of probe
Rise Time (probe only)	$\leq$ 120 ps

**Table 4: Typical electrical characteristics**

Bandwidth, (probe only)	4 GHz (See Figure 10)
Linear Input Dynamic Range	-2.0 V to +2.0 V (Equivalent to -0.4 V to +0.4 V at the output of the probe.)
Linearity	$\pm$ 0.1% over a dynamic range of -1.75 V to + 1.75 V  $\pm$ 1.0% over a dynamic range of -2.00 V to + 2.00 V
Nondestructive Input Voltage Range	-30 V to +30 V (DC + peak AC)



**Table 4: Typical electrical characteristics (Cont.)**

Input Resistance	20 kΩ at DC (See Figure 9)
Input Capacitance	1.0 pF
Offset Range	-5.0 V to +5.0 V
DC Offset Drift	150 μV/°C or less at output of probe 0.75 mV/°C or less displayed on screen with TekConnect interface
DC Offset Scale Accuracy	±2% (of 5x actual probe gain)
DC Voltage Measurement Accuracy, referred to input	±(2% of input + (2% of offset) + 50 mV output offset + 20 mV linearity error)
Delay Time	5.43 ns ±0.2 ns
System Noise	300 μV <sub>rms</sub> or less at output of probe with probe tip grounded

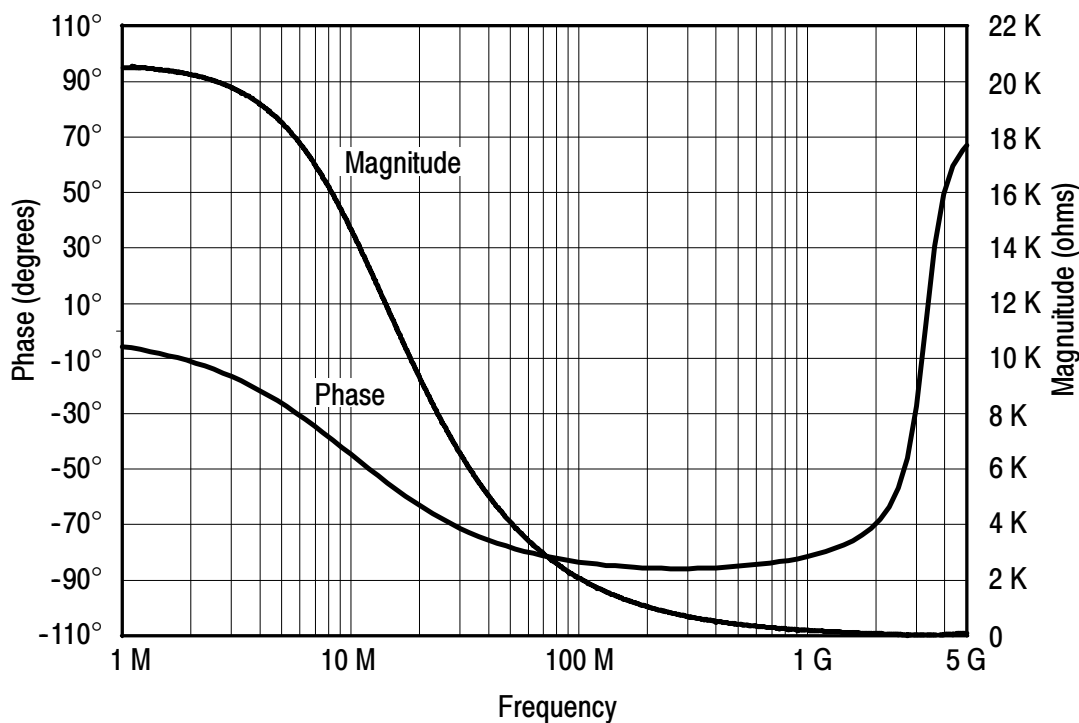

**Figure 9: Typical input impedance and phase versus frequency**

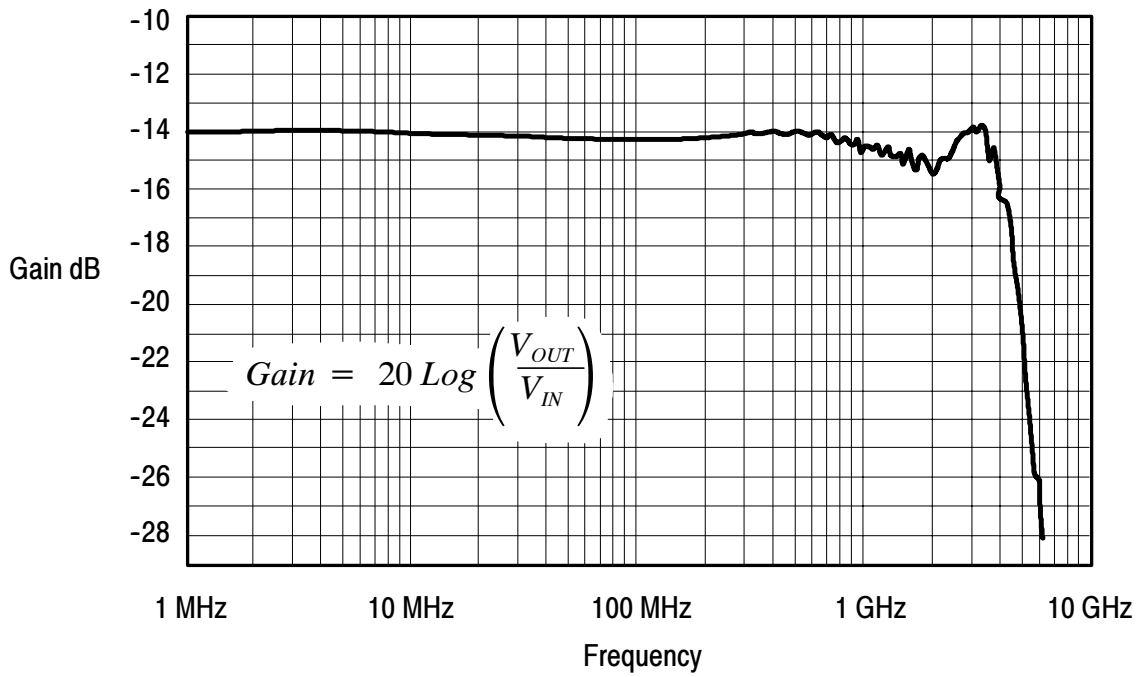

Figure 10: Typical bandwidth

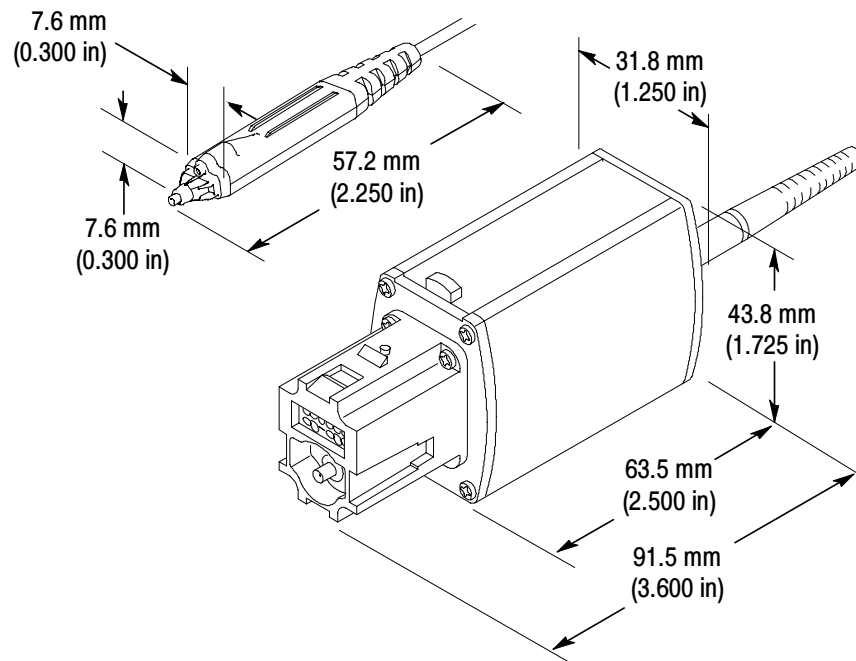

Figure 11: Probe head and compensation box dimensions

**Table 5: Physical Characteristics**

Unit weight (probe only)	223 g (7.52 oz)
Cable Length	1.3 meters (50 in)

**Table 6: Environmental characteristics**

Operating Temperature	<p>0 °C to +40 °C (+ 32 to + 104 °F)</p> <p>The environmental exposure is the procedure stated in Tektronix Design Standard 062-2847-00 for Class 5 equipment.</p>
Nonoperating Temperature	<p>-55 °C to +75 °C (-67 to + 167 °F)</p> <p>The environmental exposure is the procedure stated in Tektronix Design Standard 062-2847-00 for Class 5 equipment.</p>
Humidity	<p>0 to 90% RH at +30 °C to +40 °C (+ 86 to + 104 °F)</p> <p>The environmental exposure is as stated in Tektronix Design Standard 062-2847-00 for Class 5 equipment.</p>
Packaged Product Vibration and Shock	<p>The packaged product qualifies under the Distribution Cycle 1 Assurance Level II for packaged products 0 to 20 lbs. Test 2 for Warehouse and Vehicle Stacking (Compression) is omitted.</p> <p>Tektronix standard 062-2858-00, Rev. B, Class 5.</p>
Altitude	<p>Operating: 15,000 ft.</p> <p>Nonoperating: 50,000 ft.</p>



## Appendix B: User Service

This section details the maintenance for the P7240 probe.

### Inspection and Cleaning

To prevent damage to probe materials, avoid using chemicals that contain benzene, benzene, toluene, xylene, acetone, or similar solvents.

Do not immerse the probe or use abrasive cleaners.

Dirt may be removed with a soft cloth dampened with a mild detergent and water solution, or isopropyl alcohol.

### Calibration

If you need to do a performance verification or make internal adjustments to your probe, refer to the *P7240 4 GHz Active Probe Service Manual*, Tektronix part number 071-1056-XX. The manual is a printable pdf file, and is available on both the Tektronix website and the Optional Applications CD, Tektronix part number 063-3376-XX. The Optional Applications CD is included with Tektronix oscilloscopes featuring the TekConnect interface.

### Replacement Parts

Refer to the *Replaceable Parts* section for a list of customer replacement parts. Due to the sophisticated design of the P7240 probe, there are no user replaceable parts within the probe.

## Preparation for Shipment

If the original packaging is unfit for use or not available, use the following packaging guidelines:

1. Use a corrugated cardboard shipping carton having inside dimensions at least one inch greater than the probe dimensions. The box should have a carton test strength of at least 200 pounds.
2. Put the probe into antistatic bag or wrap to protect it from dampness.
3. Place the probe into the box and stabilize it with light packing material.
4. Seal the carton with shipping tape.



## Appendix C: Replaceable Parts

This section contains a list of replaceable parts for the P7240 probe. Use this list to identify and order replacement parts.

### Parts Ordering Information

Replacement parts are available from or through your local Tektronix, Inc. service center or representative.

Changes to Tektronix instruments are sometimes made to accommodate improved components as they become available and to give you the benefit of the latest circuit improvements. Therefore, when ordering parts, it is important to include the following information in your order:

- Part number
- Instrument type or model number
- Instrument serial number
- Instrument modification number, if applicable

If a part you order has been replaced with a different or improved part, your local Tektronix service center or representative will contact you concerning any change in the part number.

## Using the Replaceable Parts List

The tabular information in the Replaceable Parts List is arranged for quick retrieval. Understanding the structure and features of the list will help you find the information you need for ordering replacement parts.

### Item Names

In the Replaceable Parts List, an Item Name is separated from the description by a colon (:). Because of space limitations, an Item Name may sometimes appear as incomplete. For further Item Name identification, U.S. Federal Cataloging Handbook H6-1 can be used where possible.

### Indentation System

This parts list is indented to show the relationship between items. The following example is of the indentation system used in the Description column:

1	2	3	4	5	<i>Name &amp; Description</i>
					<i>Assembly and/or Component</i>
					<i>Attaching parts for Assembly and/or Component</i>
					<i>(END ATTACHING PARTS)</i>
					<i>Detail Part of Assembly and/or Component</i>
					<i>Attaching parts for Detail Part</i>
					<i>(END ATTACHING PARTS)</i>
					<i>Parts of Detail Part</i>
					<i>Attaching parts for Parts of Detail Part</i>
					<i>(END ATTACHING PARTS)</i>

Attaching parts always appear at the same indentation as the item it mounts, while the detail parts are indented to the right. Indented items are part of, and included with, the next higher indentation. Attaching parts must be purchased separately, unless otherwise specified.

### Abbreviations

Abbreviations conform to American National Standards Institute (ANSI) standard Y1.1

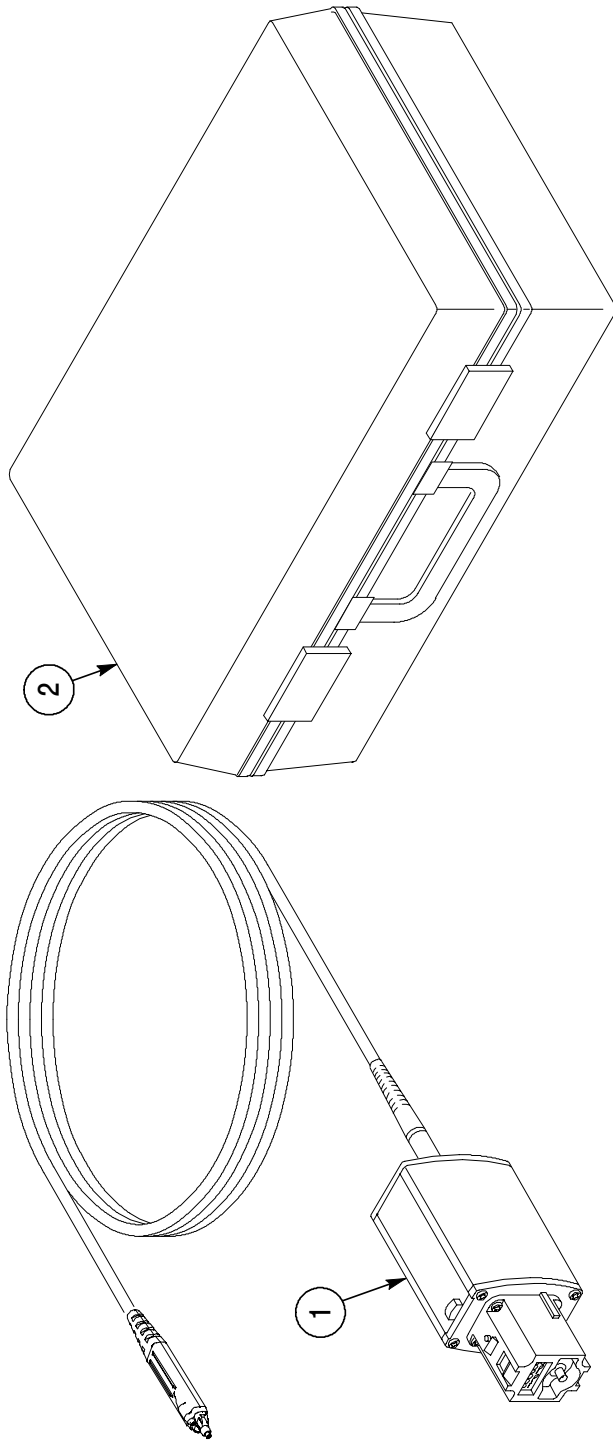
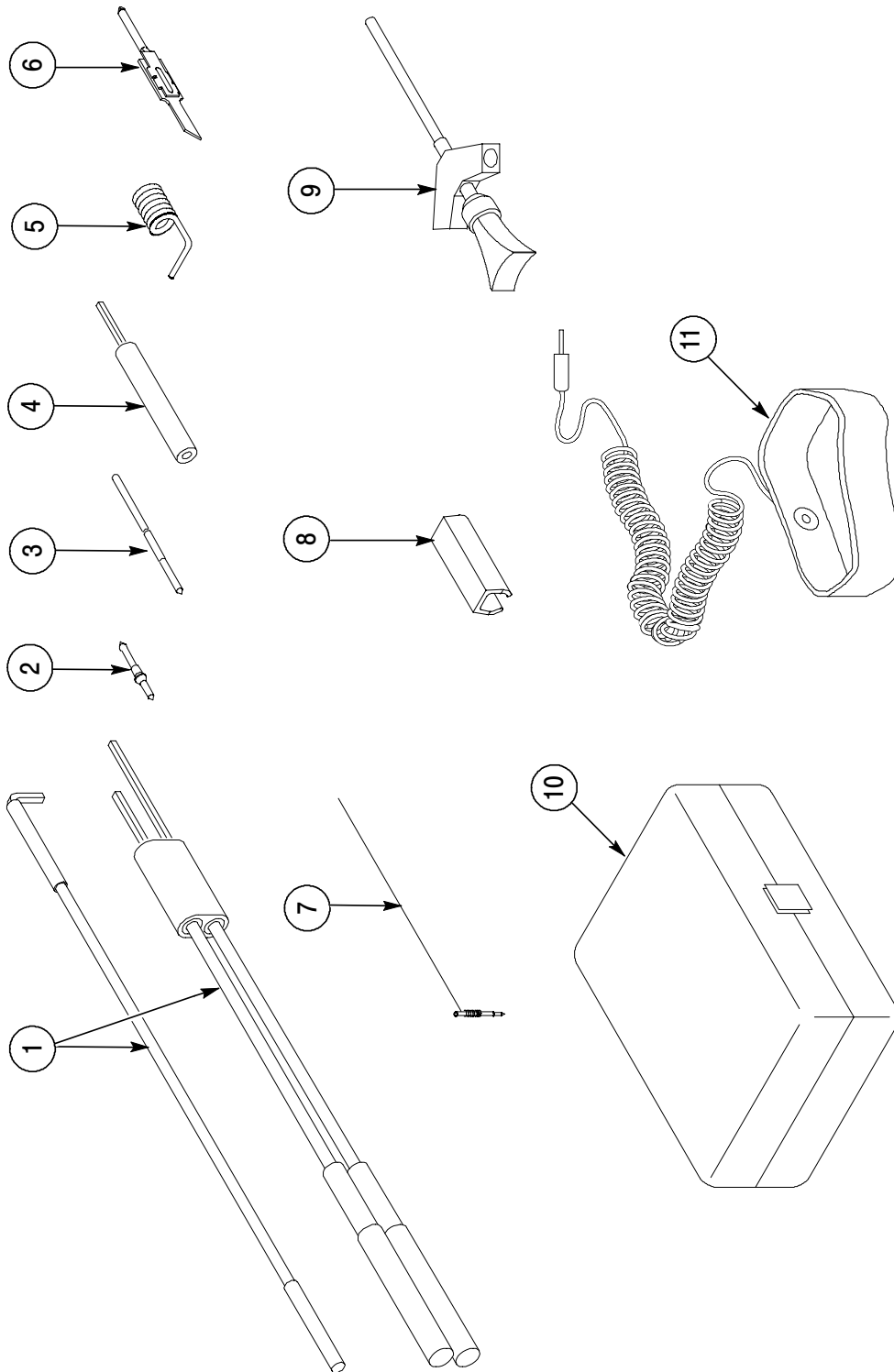

Figure 12: P7240 replaceable parts

Fig. & index no.	Tektronix part no.	Serial no. Effective	Serial no. Dscont	Qty	12345 name & description	Mfr. code	Mfr. part no.
12-1	010-0642-00			1	PROBE, FET ACT:>4 GHZ,5X,1PF,TDS SERIES	80009	010-0642-00
-2	016-1879-01			1	CASE,STORAGE:PLASTIC,W/FOAM	80009	016-1879-01





**Figure 13: P7240 standard accessories**

Fig. & index no.	Tektronix part no.	Serial no. Effective	Dscont	Qty	12345 name & description	Mfr. code	Mfr. part no.
<b>STANDARD ACCESSORIES</b>							
13-1	196-3456-00			1	LEAD SET:ACCESSORY KIT, INCL THREE 3.0 INCH GROUND LEAD, TWO DIFFERENTIAL LEAD	80009	196-3456-00
-2	131-5638-11			1	PROBE,TIP:PACKAGE OF 10	80009	131-5638-11
-3	016-1772-10			1	ACCESSORY KIT:POGO PIN,PKG OF 10	80009	016-1772-10
-4	016-1773-10			1	ACCESSORY KIT:GND PIN LENGTH ADAPTER,PKG OF 10	80009	016-1773-10
-5	016-1774-00			1	ACCESSORY KIT:ADAPTER SPRING,PKG OF 10	80009	016-1774-00
-6	-----			1	PROBE,TIP,SURETOE:PACKAGE OF 4 (REORDER ST501, PACKAGE OF 12)	80009	-----
-7	196-3482-XX			1	CUSTOMIZABLE GROUND LEAD, SET OF 5	80009	196-3482-XX
-8	016-1315-00			1	MARKER KIT,ID:CABLE MARKER BAND,2 EA, VAR COLRS	80009	016-1315-00
-9	206-0364-XX			2	TIP,PROBE:MICROCKT TEST,SMT KLIP CHIP	80009	206-0364-XX
-10	006-7164-00			1	BOX,PLASTIC:4.625 X 2.875 X 1.0	80009	006-7164-00
-11	006-3415-04			1	STRAP,WRIST:3M TYPE 2214, ADJUSTABLE,6 FT COILED CORD	TK0623	RTI 8454001829
	071-0759-XX			1	MANUAL,TECH:USER,P7240	80009	071-0759-XX

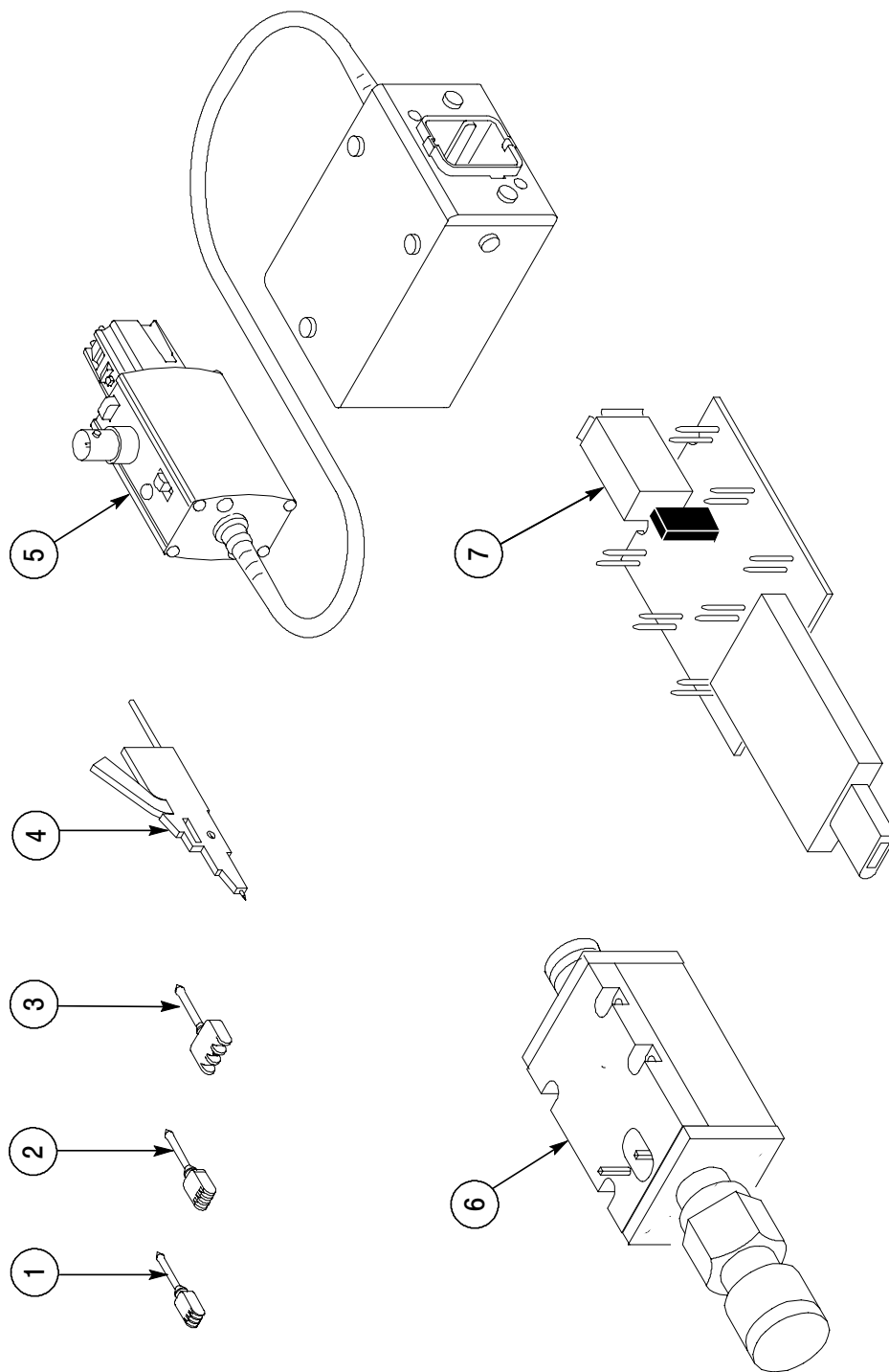

**Figure 14: P7240 optional accessories**

Fig. & index no.	Tektronix part no.	Serial no. Effective	Discont	Qty	12345 name & description	Mfr. code	Mfr. part no.
<b>OPTIONAL ACCESSORIES</b>							
14-1	SF503			1	ADPTR,SUREFOOT:0.5 MM EIAJ,PKG OF 12	80009	SF503
-2	SF502			1	ADPTR,SUREFOOT:25 MIL JEDEC,PKG OF 12	80009	SF502
-3	SF501			1	ADPTR,SUREFOOT:50 MIL JEDEC,PKG OF 12	80009	SF501
-4	SMK4			1	TIP,PROBE:MICROCKT TEST,PKG OF 4	80009	SMK4
-5	067-0422-00			1	CALIBRATION FIXTURE ASSY:ECB TO TOP,P7000 SERIES	80009	067-0422-00
-6	015-0678-00			1	ADAPTER, PROBE:TIP,SMA 2 COMPACT SIZE, TERMINATED INTO 50 OHM TEST FIXTURE	80009	015-0678-00
-7	679-5027-00			1	CKT BD SUBASSY:1394 ADAPTER	80009	679-5027-00
	063-3376-XX			1	SOFTWARE PKG:OPTIONAL APPLICATIONS SOFTWARE,CD-ROM,TDS7000 SERIES	80009	063-3376-XX

**CROSS INDEX - MFR. CODE NUMBER TO MANUFACTURER**

<b>Mfr. Code</b>	<b>Manufacturer</b>	<b>Address</b>	<b>City, State, Zip Code</b>
80009	TEKTRONIX INC	14150 SW KARL BRAUN DR PO BOX 500	BEAVERTON OR 97077-0001
TK0623	GENERAL TOOL & SUPPLY CO	2705 NW NICOLAI ST	PORTLAND, OR 97210